

E1100WX3W1

Part number	E1100WX3W1
Structure	Horizontal
Actuator configuration	Optional
Actuator length	Optional
Number of detent	Optional

Number of pulse	Optional
Push-on switch	Without
Travel of push-on switch	Without
Operating temperature range	-40°C~+85°C

Electrical characteristics

Ratings	10mA 5V DC
Output signal	Two phase A and B
Max./min. operating current (Resistive load)	10mA/1mA
Insulation resistance	100M Ω min., 250V DC
Voltage proof	300V AC for 1 min. or 360V AC for 2s

Mechanical characteristics

Rotational torque	10 \pm 7mN.m
Push-pull strength	100N

Durability	Operating life	30.000 cycles
MOQ		1.000pcs

Photo

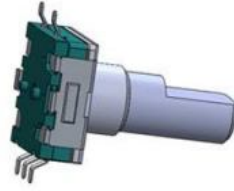

Dimensions

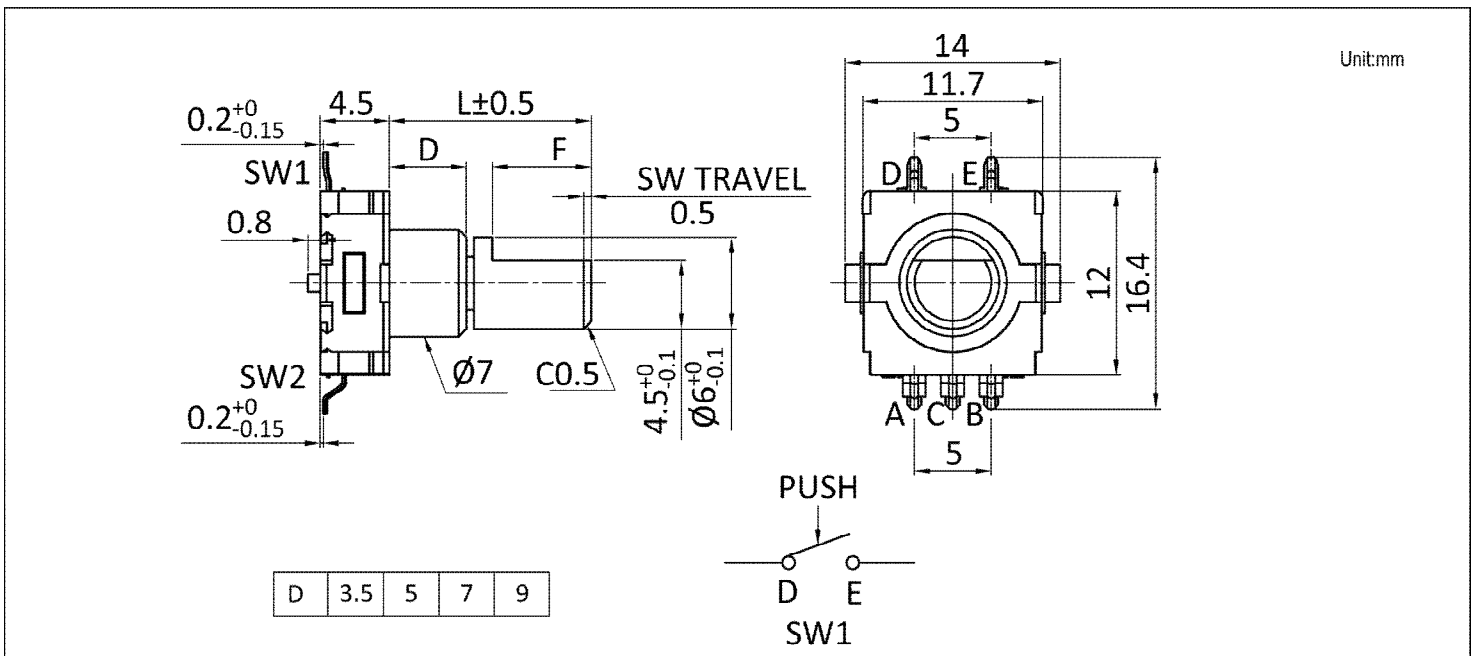

Mounting Hole Dimensions

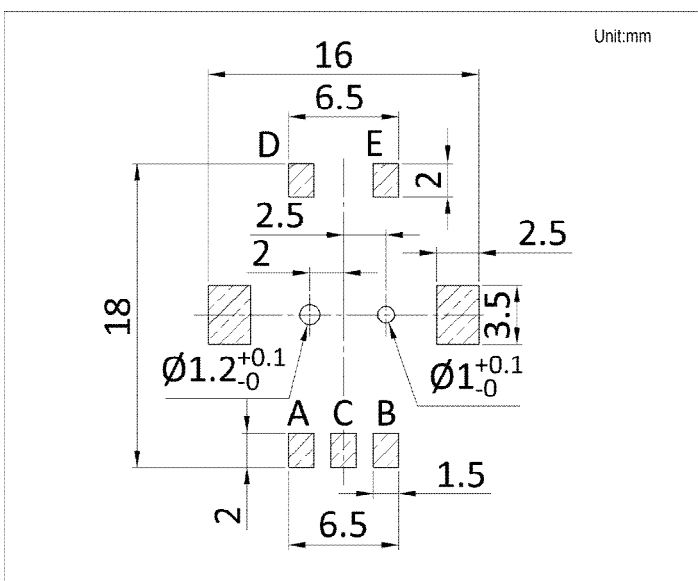

Output Wave

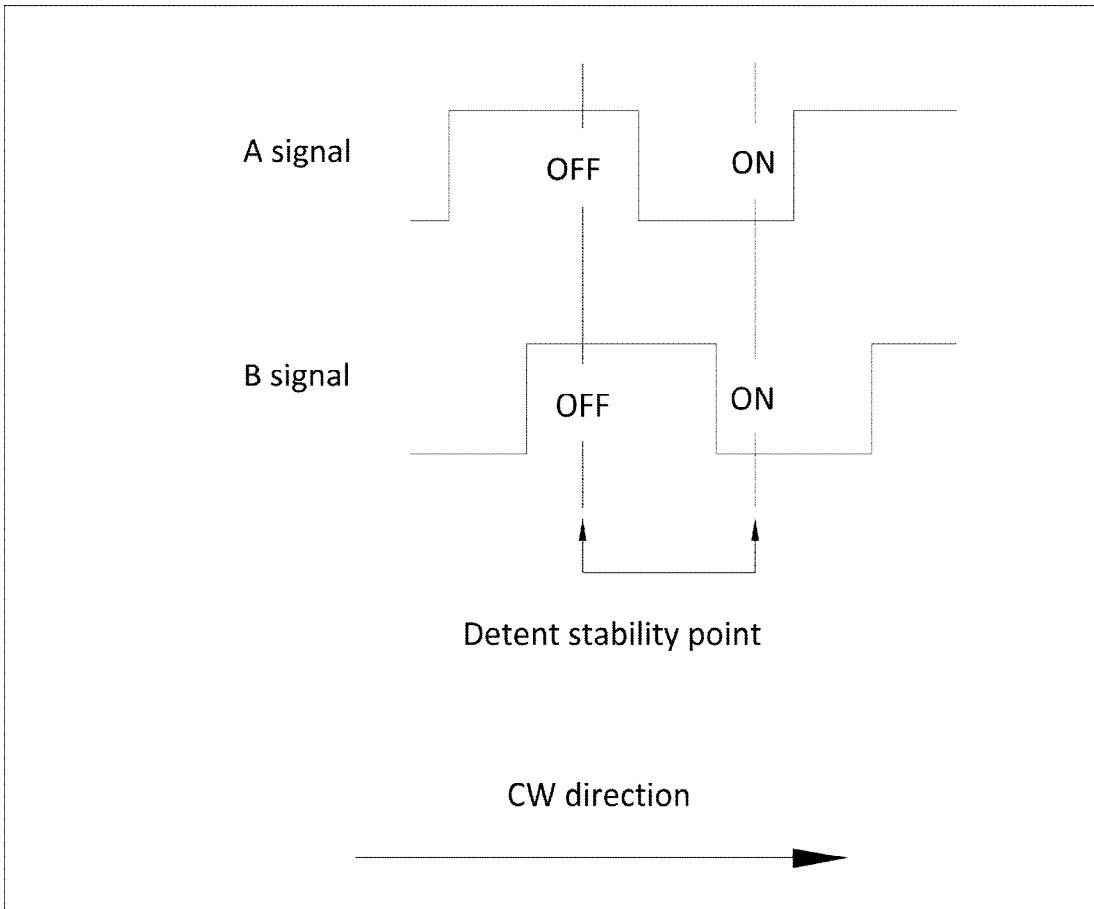

Sliding Noise

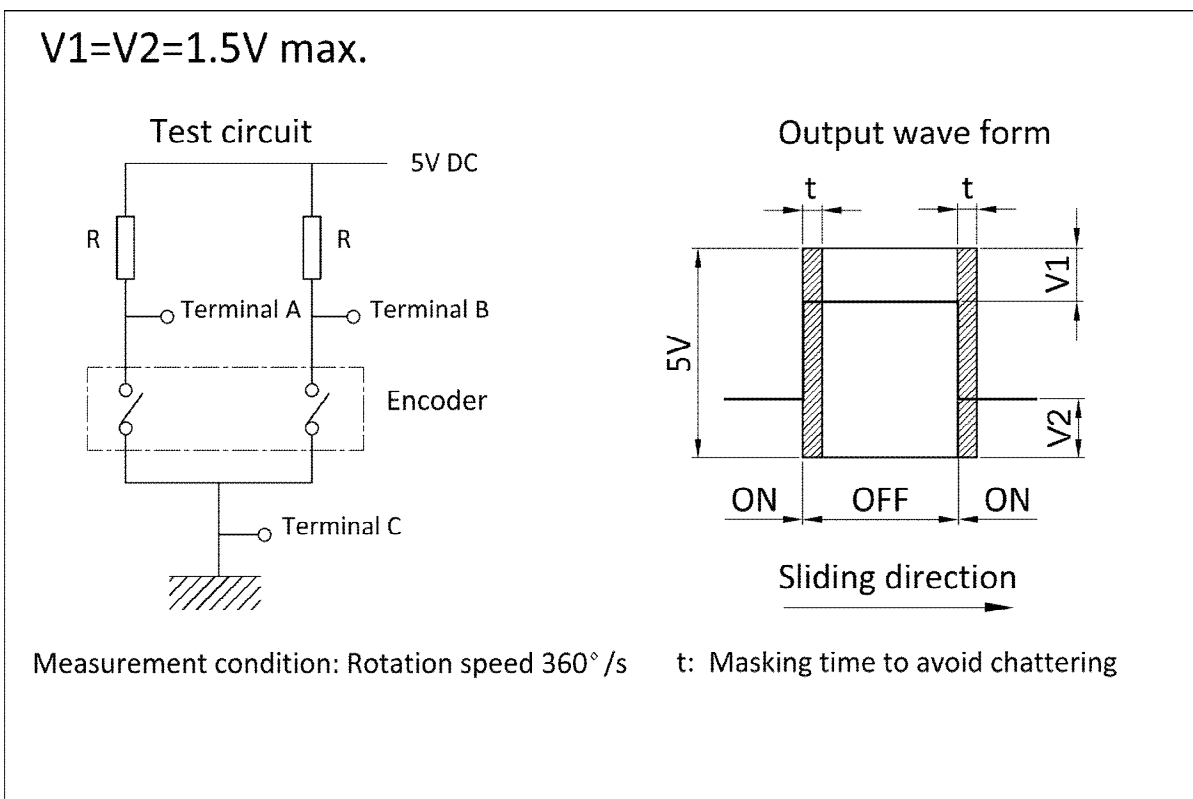

Pulse and Detent Options

Pulse	Detent	Direction
15	15	F
	30	F
20	20	F
		R

Shaft and Shaft Length Options

Shaft type: A1

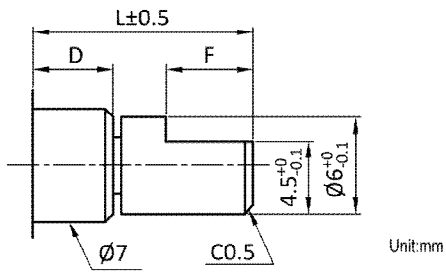

D=5							
L	10	11.5	12	12.5	13	13.5	15
F	4	5	5	5	5	5	7
D=7							
L	13	15	16.5	17	19	20	20
F	4	7	7	7	7	10	12
D=9							
L	17.5	18	22.5	23	25	26.5	30.5
F	7	7	7	8	7	10	8

Shaft type: F1

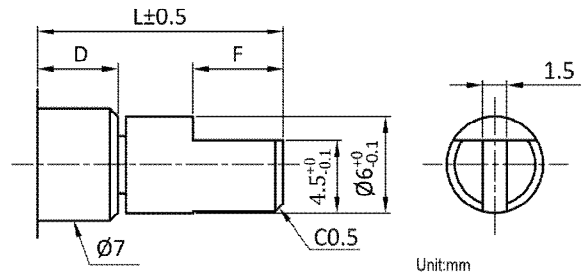

D=5							
L	10	10.5	12	13	13.5	15	15.5
F	4	4	5	6	5	5	7
D=7							
L	16.5	17.5	18.5	20	20		
F	7	8	7	5	11.5		
D=9							
L	29.5						
F	12						

Shaft type: K1

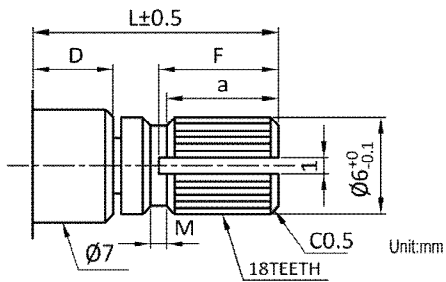

D=5	
L	17.5
F	6
a	5
M	1
D=7	
L	16
F	5
a	4
M	1

Shaft type: V1

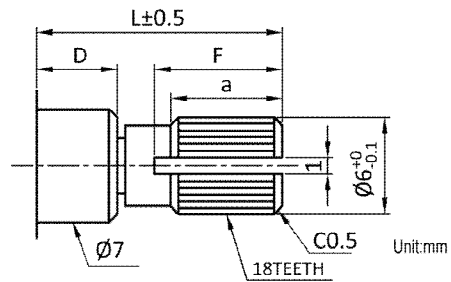

D=5							
L	10	10.5	11.5	12	13	13.5	15
F	3	4.5	5	5	5	6	8
a	4	4	5	5	6	7	8
D=7							
L	18	20	23.5				
F	9	7	10				
a	9	7	10				
D=9							
L	24.5						
F	13						
a	13						

Shaft type: T1

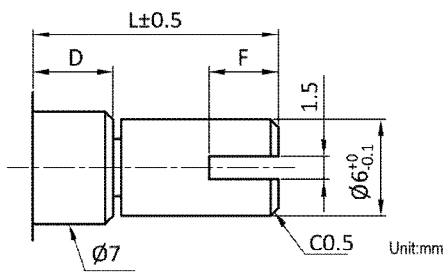

D=5		
L	11	15
F	3.5	5
D=7		
L	20.5	
F	8	

Shaft type: T2

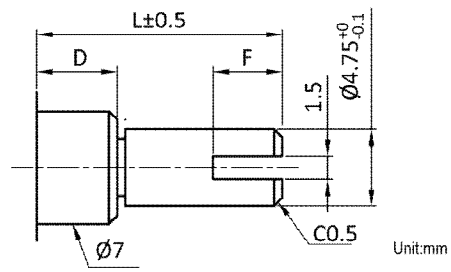

D=5		
L	15	17
F	2	7

Packing specifications

Quantity per carton	2.000pcs
Packing method	Foam box
Carton dimension	460X285X310mm

Soldering conditions

Wave soldering

Soldering surface temperature	100°C max.
Heating time	2 min. max.
Soldering temperature	260°C \pm 5°C max.
Soldering time	5 \pm 1s
No. of solders	2 time max.

Hand soldering

Tip temperature	350°C max.
Soldering time	3s max.
No. of solders	1 time