

型号	W
S1201AC0103VX	5
S1202AC0103VX	8

C. C. W FULL POSITION

H	X
10.0	1
12.5	2

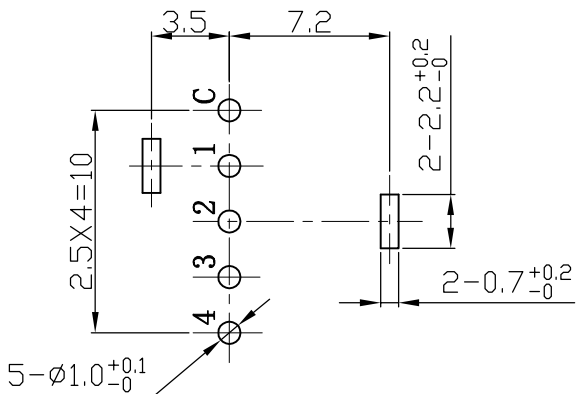

P. C. B LAY OUT

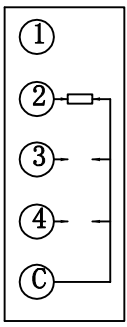

CIRCUIT DIAGRAM

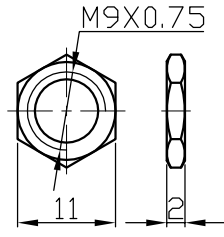

NUT 1PCS

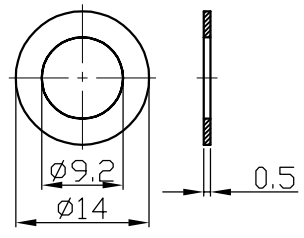

WASHER 1PCS

**FB Shaft Style**

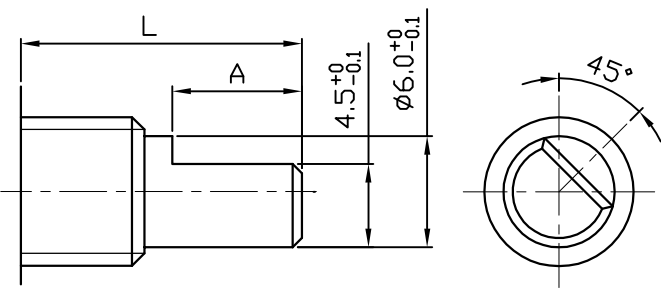

**KR Shaft Style**

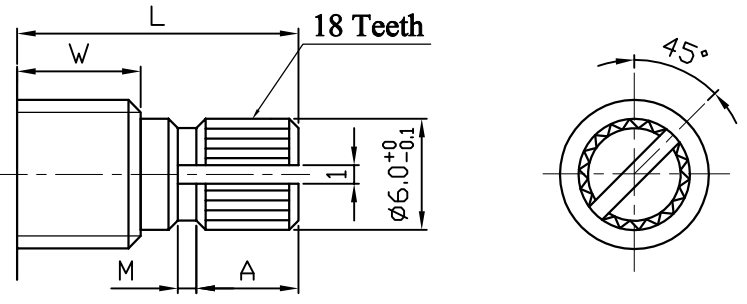

L	15	20	25	30
A	7	12	12	12

L	10	12	14	15	20	25	30
A	3.5	5	6.5	7	12	12	12
M	1	1	1	1	2	2	2

01	-	-	04	-	-
00	ORIGINAL DRAWING	2016. 03. 19	03	-	-
.ISSU.	REVISION	DATE	02	-	-

			TOL. UNLESS OTHERWISE SPEC.	
			BASIC DIMENSIONS	TOL.
			L ≤ 10	±0.3
DSGD.	CHKD.	APPD.	10 < L	±0.5
	SCALE	-	100 ≤ L	±0.8
	UNIT	mm	ANGLE	±5°

深圳明佳创新电子有限公司

MODEL: 见上表

DRAWING NO: MJ-S12-0004

# 深圳明佳创新电子有限公司

## 電位器規格書 SPECIFICATIONS

適用型號 : S12 系列  
APPLICABLE MODELS : S12 Series

### 一 構造 CONSTRUCTION

形狀,寸法,依照圖面規定

外觀 各部應良好無銹蝕、裂痕、電鍍不良現象  
APPEARANCE : EVERY PART SHOULD BE FINISHED NOT TO EXIST RUSTFLAW CRACK AND PLATING

### 二 機械的性能 (Mechanical characteristics)

ITEM 項目	SPECIFICATIONS 規格
全轉角度： Total rotational angle	30°± 3°
回轉力矩： Rotational torque	200~600gf. cm
回轉止動強度： Rotational stopper strength	5Kgf.cm Min
軸抗推拉強度： Push-pull strength	Pull:8kgf Push:8kgf Min at 10 sec
軸搖晃度： Shaft wobble	0.7*L/30mm (P-P)L=shaft Length.
軸套螺紋緊固強度： Bushing nut tighten strenngth	7Kgf.cm Min
軸向間隙： Shaft play in axial direction	0.4mm Max
軸的回轉方向擺動： Shaft play in rotational wobble	5° Max
定位脫出矩： Click torque	500±200gf. cm

### 三 電氣的性能 (Electrical characteristics)

ITEM 項目	SPECIFICATIONS 規格
額定功率： Rated power	DC 16V 3A Max
極數： poles	<input type="checkbox"/> 1 <input type="checkbox"/> 2 <input type="checkbox"/> 3 <input type="checkbox"/> 4 <input type="checkbox"/> 5 <input type="checkbox"/> 6
段數： Sections	<input type="checkbox"/> 2 <input type="checkbox"/> 3 <input type="checkbox"/> 4 <input type="checkbox"/> 5 <input type="checkbox"/> 6
接觸電阻： Contact resistance	≥ 50MΩ
絕緣阻抗： Insulation resistance	100MΩ min. at 500V DC



# 深圳明佳创新电子有限公司

## 電位器規格書 SPECIFICATIONS

耐電壓： Voltage proof	1minute at 500V AC				
<b>四 耐久性能(Durability)</b>					
ITEM 項目	SPECIFICATIONS 規格				
盐雾试验 Salt mist	8H				
回轉壽命： Rotational life	$\geq 10,000$ cycles				
<b>五 其他性能 (Else)</b>					
ITEM 項目	SPECIFICATIONS 規格				
儲存溫度： Storage Temperature Range	-40°C ~ +85°C				
使用溫度： Operaating Temperature Range	-30°C ~ +80°C				
焊錫耐熱性： Resistance To Soldering Heat	波峰焊錫： Less than 260 ± 5°C and quicker than 3 ± 1seconds 手工焊錫： Less than 300 ± 5°C and quicker than 3 ± 1seconds				
制 定 日 期 Rstabilh date	2015-10-19	APPD 核准	CHKD 审核	DSG 制定	DOCUMENTNO 文号
版本号:A.0	变更记录				R11101-0001