

Dimensions

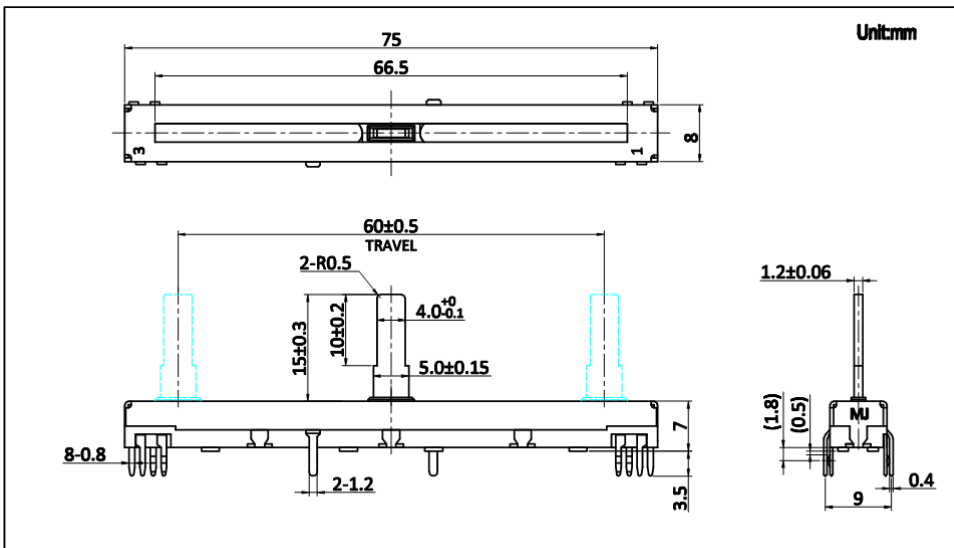

Mounting Hole Details

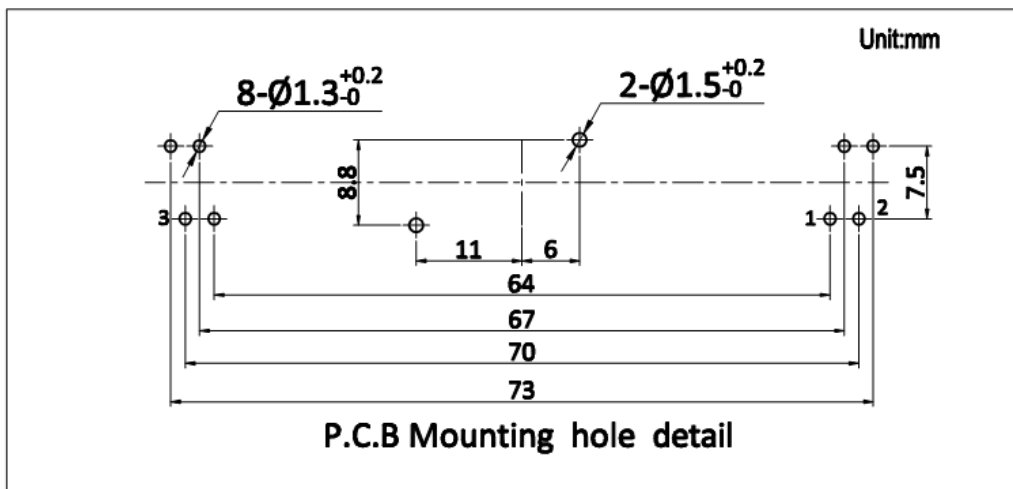

Circuit Diagram

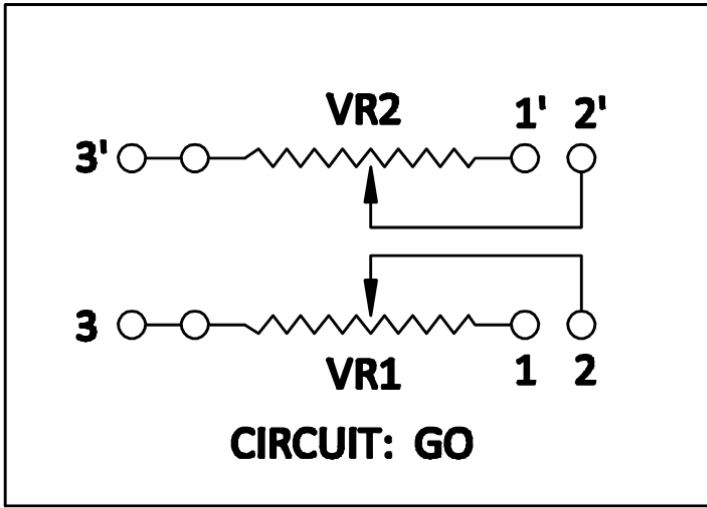

Resistance Taper Options

A Taper	B Taper	C Taper	MN
05 A	1 B	05 C	M
10 A	2 B	10 C	N
15 A	3 B	15 C	
20 A	4 B	20 C	
25 A		25 C	
30 A		30 C	

Packing specifications

Quantity per carton	528pcs
Packing method	Option
Carton dimension	460X285X310mm

Soldering conditions

Wave soldering

Soldering temperature	260°C ±5°C max.
Soldering time	5 ±1s
No. of solders	1 time max.

Hand soldering

Tip temperature	350°C max.
Soldering time	3s max.
No. of solders	1 time